

A Study on the Fuzzy Controller for an Unmanned Surface Vessel Designed for Sea Probes

SooHong Park*, Jongkwon Kim**, Wonbo Lee***, Cheolsoo Jang****

* Department of Mechatronics Engineering, Dongseo University, Sasang Ku, Pusan 617-716, Korea
(Tel : 82-51-320-1765; Fax : 82-51-320-1751 ; E-mail:shpark@dongseo.ac.kr)

** Shin Dong Digitech Co., Ltd., 3F, Jinyoung Bldg, 1213-1, Choryang-1 Dong, Pusan 601-839, Korea
(Tel : 82-51-742-3811; Fax : 82-51-746-3813 ; E-mail:jkkim@shindong.com)

*** Shin Dong Digitech Co., Ltd., 3F, Jinyoung Bldg, 1213-1, Choryang-1 Dong, Pusan 601-839, Korea
(Tel : 82-51-917-8307; Fax : 82-51-467-5002 ; E-mail:wblee@shindong.com)

**** Shin Dong Digitech Co., Ltd., 3F, Jinyoung Bldg, 1213-1, Choryang-1 Dong, Pusan 601-839, Korea
(Tel : 82-51-466-5270; Fax : 82-51-467-5002 ; E-mail:csjang@shindong.com)

Abstract: Recently, the applications of unmanned system are steadily increasing. Unmanned automatic system is suitable for routine mission such as reconnaissance, environment monitoring, resource conservation and investigation. Especially, for the ocean environmental probe mission, many ocean engineers had scoped with the routine and even risky works. The unmanned surface vessel designed for sea probes can replace the periodic and routine missions such as water sampling, temperature and salinity measuring, etc. In this paper, an unmanned surface vessel was designed for ocean environmental probe missions. A classical and an adaptive fuzzy control system were designed and tested for the unmanned surface vessel. The design methodologies and performance of the surface vessel and fuzzy control algorithm were illustrated and verified with this unmanned vessel system designed for sea probes.

Keywords: Unmanned Surface Vessel, Fuzzy Control, Fuzzy-PID, Automatic route Tracking Control.

1. Introduction

The unmanned surface vessels are remotely piloted or self-piloted ships. Recently, their abilities are much more that they carry GPS, radar, sonar, cameras, sensors, communication equipments, or other payloads. Such unmanned automatic vessel system is suitable for routine mission such as reconnaissance, environment monitoring, resource conservation and investigation. Especially, for the ocean environment monitoring mission, many ocean engineers had scoped with the routine and even risky works. The automatic system can replace the periodic and routine missions: water sampling, temperature and salinity measuring, etc. Some day several unmanned system will be operated in military purposes such as reconnaissance, surveillance, and intelligence of enemy forces without risking the lives of crews. These actual applications need more versatile performance. Among these abilities autonomous stabilization, collision avoidance and navigation abilities are necessarily needed. It is necessary to design a feedback control system with adequate closed loop bandwidth. This paper was concentrated on describing the functional design, electronic equipments and their interconnections for acquiring autonomous navigation. The autopilot or *automatic pilot* is a device for controlling an aircraft, ship or other vehicles without constant human intervention. For ships, course-keeping capabilities were the first applications. Modern autopilots can execute complex maneuvers like turning, docking operations, or make possible the control of inherently unstable vessels. Autopilots are used to steer surface ships, submarines, torpedoes, missiles, rockets, and spacecraft among others. A classical and an adaptive fuzzy control system were designed and tested for the unmanned surface vessel.

The design methodologies and performance of the surface vessel and fuzzy control algorithm were illustrated and verified with this unmanned vessel system designed for sea probes.

2. Equation of Motion for the Surface Vessel

2.1 Equation of Motion for Yaw autopilot

Generally, control dynamic equation of ship is described by nonlinear equation owing to the nonlinear fluid force produced by ship hull, thruster and rudder or the effect of interference of fluid viscosity and inertia. The linearized equation of control dynamic equation is widely used. The 2nd order Nomoto ship dynamic equation is that yaw angle velocity is only function of rudder control input, δ . The resulting equation is as following equation (1).

$$T_1 T_2 \ddot{\gamma} + (T_1 + T_2) \dot{\gamma} + \gamma = K \delta + K T_3 \dot{\delta} \quad (1)$$

where, T_1 , T_2 are command following and, stability coefficients respectively. T_3 is coefficient which affects on the rudder of differential control effect and increases path stability. K is coefficient related to rotation ability.

From equation (1), in a non-periodic motion such as control motion, low frequency motion, a simplified 1st order Nomoto response model can be used as following equation (2).

$$\dot{\gamma} = -\frac{1}{T} \gamma + \frac{K}{T} \delta \quad (2)$$

where, γ is yaw angle velocity, δ is rudder control angle, K and T are characteristic constants of the ship.

2.2. Equations of Yaw Angle Command

Figure 1 represents the coordinate system used for ship motion control. Coordinate system OX_0Y_0 is inertia coordinate. The ship path and ship motion with respect to this inertia coordinate system.

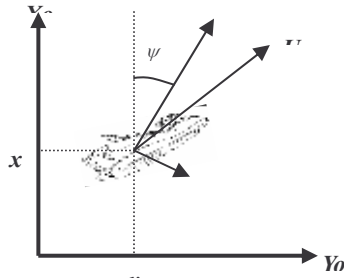

Fig. 1. Coordinate System for Ship Motion

ψ is yaw angle, the angle between true north and heading of the ship. u and v are forward and transverse velocity respectively. x and y are position of the ship. The motion equation can be derived from above figure 1.

$$\begin{aligned} \dot{x} &= u \cos \psi - v \sin \psi \\ \dot{y} &= u \sin \psi + v \cos \psi \\ \dot{\psi} &= \gamma \end{aligned} \tag{3}$$

An automatic route tracking control algorithm is represented in figure 2. If the vessel is off the desired target path, position error between present and target position of the ship is occurred by calculation of the GPS signals. To navigate exact path of the ship, appropriate yaw angle command which reduce this position error must be generated.

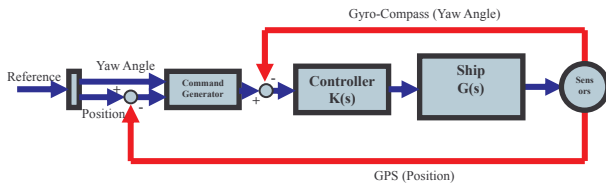

Fig. 2. Function Diagram of Unmanned Surface Vessel

In straight navigation path, the position error (P_e) between the desired target position (P_d) and present position of the ship (P) can be defined by the following equation.

$$\vec{P}_e = P_d - P = \begin{bmatrix} x_d - x \\ y_d - y \end{bmatrix} \tag{4}$$

By using equation (3), the equation can be described in the function of desired yaw angle ψ_d and present yaw angle ψ of the ship.

$$\vec{P}_e = \begin{bmatrix} x_d - x \\ y_d - y \end{bmatrix} = \begin{bmatrix} u \cos \psi_d - u \cos \psi \\ u \sin \psi_d - u \sin \psi \end{bmatrix} \tag{5}$$

Summarize with respect to ψ ,

$$\psi = \psi_d - \psi_{P_e} \tag{6}$$

$$\psi_{P_e} = \cos^{-1} \left(1 - \frac{P_e^T P_e}{2u^2} \right) \tag{7}$$

where, differentiate position error P_e with respect to time the following equation is acquired. The position error can be reduced by adding this ψ_{P_e} to the yaw angle.

2.3 LOS Guidance and Navigation

The LOS vector for LOS guidance was shown in Figure 3.

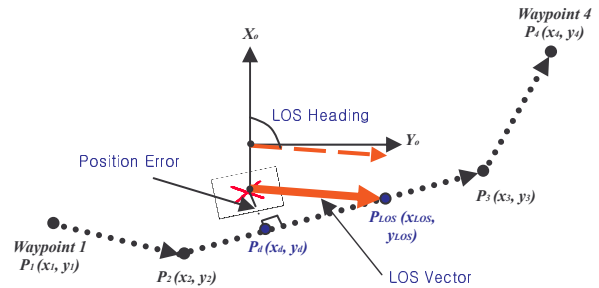

Fig. 3. Schematic Figure of a Vehicle LOS Guidance

The perpendicular position error between present position and desired position $P_d(x_d, y_d)$ of a vehicle are like following equation.

$$x_d = x_2 + t_h(x_3 - x_2) \tag{8}$$

$$y_d = y_2 + t_h(y_3 - y_2) \tag{9}$$

$$p_e = \sqrt{(x - x_d)^2 + (y - y_d)^2} \tag{10}$$

Where,

$$t_h = \frac{(x_3 - x_2)(x - x_2) + (y_3 - y_2)(y - y_2)}{\sqrt{(x_3 - x_2)^2 + (y_3 - y_2)^2}} \tag{11}$$

The heading angles from position 2 to 3 and at position 3 are as follows,

$$\varphi_{WP_{23}} = a \tan 2(y_3 - y_2, x_3 - x_2) \tag{12}$$

$$\varphi_{WP_3} = a \tan 2(y_3 - y, x_3 - x) \tag{13}$$

The heading angle from vehicle to LOS Position is given following equations.

$$\varphi_{LOS} = a \tan 2(y_{LOS} - y, x_{LOS} - x) \tag{14}$$

$$x_{LOS} = x_d + L \cdot \cos \varphi_{WP_{23}} \tag{15}$$

$$y_{LOS} = y_d + L \cdot \sin \varphi_{WP_{23}} \tag{16}$$

Where, L is the distance between desired position P_d and LOS position.

2.4. 1 DOF autopilot Model (Yaw Subsystem)

A linear autopilot model for course control can be derived from the maneuvering model

$$M \dot{v} + N(u_0)v = b \delta \tag{17}$$

where, $v = [u, v, w, p, w, r]^T$, by defining the yaw rate r as output:

$$r = c^T v, \quad c^T = [0, 1] \tag{18}$$

Hence, application of the Laplace transformation yields :

$$\frac{r}{\delta}(s) = \frac{K(1 + T_3s)}{(1 + T_1s)(1 + T_2s)} \tag{19}$$

This is referred to as Nomoto's 2nd-order response equation.

2.5. Fuzzy Controller

A general structure of Fuzzy controller was represented in figure 4. The Fuzzy controller has a Fuzzifier, a Fuzzy inference engine and a Defuzzifier. The Fuzzy inference engine is composed of Fuzzy rule base. In figure 5, the Fuzzy-PID algorithm, used in this paper, was represented. It has three inputs(error, error rate, error acceleration) and two Fuzzy control blocks.

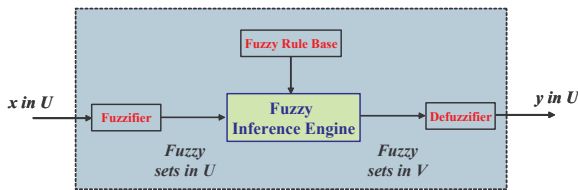

Fig. 4. Structure of Fuzzy Controller

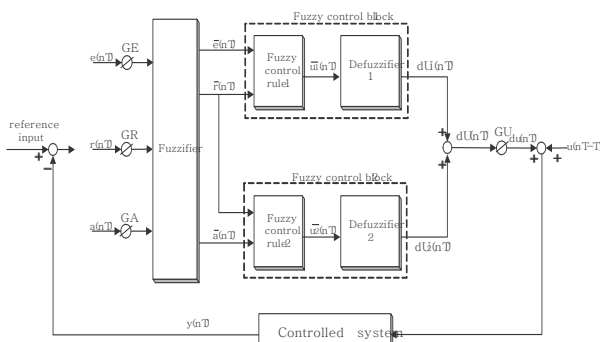

Fig. 5. Structure of Fuzzy-PID Controller

3. System Design of the Unmanned Vessel

3.1. System Design

The test unmanned surface vessel was made by modifying and installing necessary navigation sensor on a water- jet ski. The vessel has a 85 horsepower 718 cc 2 cylinder engine. The dry weight is 174 kg and has Length 254 cm. It had equipped many navigation sensors, such as, GPS, DGPS, sonar, speed meter and so on. Also, it had many onboard environmental

sensors, such as, anemometer, water temperature sensor, salinity sensor, OCM(Ocean Color Monitoring) sensor and so on

3.2. Fuzzy Controller Design

A Fuzzy-PID Controller was designed for the unmanned surface vessel. In Figure 6, the input membership function for error, error rate, and error acceleration were represented. EN, EP, RN, RP, AN and AP are error negative, error positive, error rate negative, error rate positive, error acceleration negative and error acceleration positive, respectively. In Figure 7, the output membership function of control block 1 was represented. ON OZ, and OP are output negative, output zero, and output positive, respectively. Also, the output membership function of control block 2 was represented on the Figure 8. OMN and OPM are output middle negative and output positive middle, respectively.

4. Simulations

The Fuzzy controller for unmanned surface vessel system was design and the performances were verified with computer simulations. Matlab and SIMULINK were used for these simulations. A Fuzzy rule based controller was designed and the performance of yaw angle for the surface vessel was simulated. For the availability test for the designed Fuzzy controller, the comparison with conventional PID controller was performed. The conventional PID controller has fixed control gains but Fuzzy-PID controller has variable PID control gains. Figure 8 shows the step response of Fuzzy-PID control system and PID control system. This result shows that the Fuzz-PID controller is better performance. Figure 9 shows the sine route tracking response of Fuzzy-PID control system and PID control system. This yaw angle control system showed reasonable performance. Solid blue line is target and dashed red line is controlled yaw response. The performance of Fuzzy-PID is also superior then the conventional PID controller. Thus results are due to the variable gain of Fuzzy-PID controller and early adaptation of error. The final steady state PID control gains are all same for two controllers. In all cases, from these simulations, the performance of Fuzzy-PID controller is superior then conventional fixed gain PID controller.

4. Conclusions

The unmanned surface vessel system was design and functional system performances were studied. A computer based Fuzzy-PID controller was designed and the performance of yaw angle of the vessel was simulated and tested in several conditions. The comparison with Fuzzy-PID and conventional PID controller was performed. In all cases, the performance of Fuzzy-PID controller is superior then conventional fixed gain PID controller. System configuration and interference was also tested for the designed unmanned vessel. The design methodologies and performance of the surface vessel were illustrated and verified with a linearized equation of motion. A linear autopilot model for course control can be derived from the maneuvering model and a linear controller was designed and tested for this unmanned surface vessel. The yaw angle showed reasonable responses under offshore environmental wind and wave conditions. Therefore, designed unmanned

marine vessel system and controller will be useful for advanced real embedded platform. And the nonlinear model will be used in the hardware-in-the-loop simulation to check out control software. The state estimation method such as Kalman filter is required for robust to short GPS outages. Also, it is required that the RTOS(Real Time Operating System) and more advanced adaptive fuzzy control algorithms for autopilot control system.

References

[1] Strand, J. P. and A. J. Sørensen, "Marine Positioning Systems" *Ocean Engineering Handbook* (F. El-Hawary, Ed.). Chap. 3, pp. 163-176. CRC Press, USA, 2000.

[2] Sælid, S. and N.A. Jenssen, "Adaptive Ship Autopilot with Wave Filter", *Modeling, Identification and Control* MIC-4(1), 33-46, 1983.

[3] Trygve Laudval & Thor I. Fossen, "Robust Adaptive Ship Autopilot with Wave Filter and Integral Action," To appear in the Special Issue on Marine Systems Control, *International Journal of Adaptive Control and Signal Processing*, 1998.

[1] Fossen, T. I, *Guidance and Control of Ocean Vehicles*, John Wiley & Sons Ltd., 1994.

[2] Husa, K. E, and Fossen, T. I, "Backstepping Designs for Nonlinear Way-Point Tracking of Ships," *Proceedings of the 4th IFAC Conference on Manoeuvring and Control of Marine Craft*, 1997.

[3] Fossen, T. I, *Marine Control Systems*, Marine Cybernetics, 2002.

[4] Lin, C. L, and Su, H. W, "Intelligent Control Theory in Guidance and Control System Design : an Overview," *Proceedings National Science Council ROC(A)*, Vol. 24 No 1, pp 115 ~ 20, 2000.

[5] Ha, I, and Chong, S, "Design of a CLOS guidance law via feedback linearization," *IEEE Transactions on Aero-space and Electronic Systems*, Vol. 28 No 1, pp. 51 ~ 63, 1992.

[6] Breivik, M, and Fossen, T. I, "Line-of-Sight Path Following for Marine Surface Vessels," *Proceedings of the IFAC*, 2004.

[4] Strand, J. P., "Nonlinear Position Control Systems Design for Marine Vessels", PhD thesis, Department of Engineering Cybernetics, Norwegian University of Science and Technology. Trondheim, Norway, 1999.

[6] Sarpkaya, T., "Mechanics of Wave Forces on Offshore Structures", Van Nostrand Reinhold Company. New York, NY, 1981.

[7] Thor I. Fossen & Kunt Eilif Husa, "Backstepping Designs for Nonlinear Way-Point Tracking of Ships," *The 4th IFAC Conference on Maneuvering and Control of Marine Craft(MCMC)*, 1997.

[8] Trygve Laudval & Thor I. Fossen, "A Globally Stable Adaptive Ship Autopilot With Wave Filter Using Only Yaw Angle Measurements," *Proceedings of the 3rd IFAC Workshop on Control Application in Marine Systems (CAMS' 95)*, pp.262 ~ 269, May 1995.

[9] Trygve Laudval & Thor I. Fossen, "Nonlinear Rudder-Roll Damping of Non-Minimum Phase Ships Using Sliding Mode Control," *Proceedings of the European Control Conference*, 1997.

[10] Savage, P.G., "Strapdown Inertial Navigation", Lecture Notes, Strapdown Associates Inc., Minnetonka, MN, USA,

1990.

[11] Schuster, M. D. and S. D. Oh, "Three-Axis Attitude Determination from Vector Observations", *Journal of Guidance, Control and Dynamics* JGCD-4(1), 70-77, 1981.

[12] Sellars, F.H. and J. P. Martin, "Selection and Evaluation of Ship Roll Stabilization Systems", *Marine Technology* MT-29(2), 84-101, 1992.

[13] Sørensen, A. J., T. I. Fossen and J. P. Strand, "Design of Controllers for Positioning of Marine Vessels", *The Ocean Engineering Handbook* (F.El-Hawary, Ed.), Chap.3, pp. 207-218. CRC Press, USA, 2000.

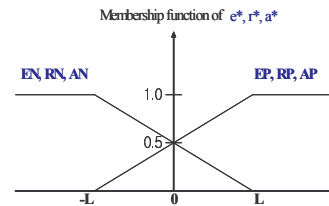
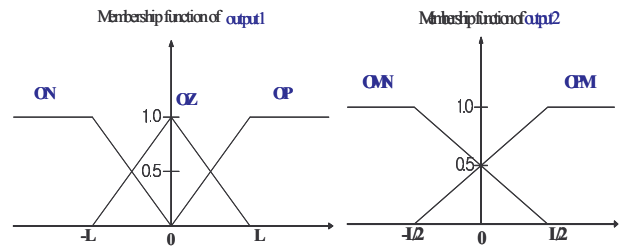

Fig. 6. Input Membership Function



(a) Block 1 (b) Block 2
Fig. 7. Output Membership Function

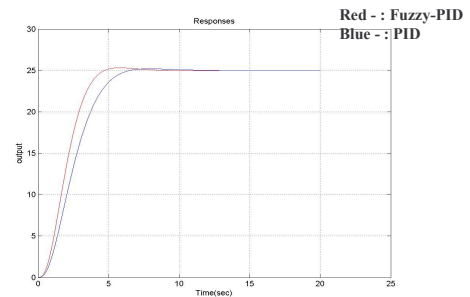

Fig. 8. Step Response of Surface Vessel Model

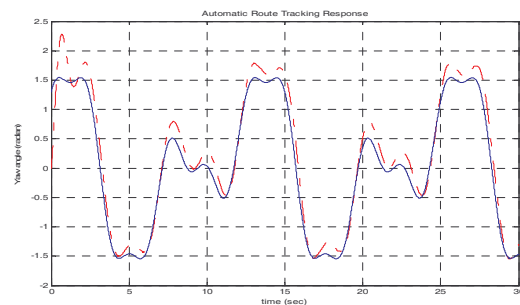

Fig. 9. Tracking Response for Surface Vessel Model